

# QL-080 COMPACT CRANE PACKAGES

**QuickLIFT**<sup>®</sup>  
COMPACT CRANES



## The perfect fit for utes and light trucks

The ultra-compact, lightweight Quicklift QL-080 cranes have been designed to be an efficient and safe replacement for manual lifting, while boosting productivity through the capacity to lift up to 700kg!

**SAFER** with load-hold valve protection and operated by radio remote so you can operate at a distance, out of harms way

**SMARTER** the cost of down-time from back injury often exceeds the cost of a compact crane

**STRONG** 700kg max lift, ultra-light crane weight

**COMPACT** only takes up a 310mm x 595mm deck footprint

**HYDRAULIC** slew, lift and extension

**VERSATILITY** Quicklift can be utilised in any industry

**HARD-WEARING** Teflon wearing pads reduce friction on hydraulic boom extensions, increasing the life span of the crane structure

**NEW ZEALAND** designed and tested, backed by a 3 year warranty with fitting agents nationwide

## Crane package includes:

Hydraulic slew and lift, hydraulic extension(s), manual extension, overload relief on lifting cylinder.

## Installation kit includes:

Base plate, outrigger socket, outrigger with manual wind down leg, bolt-down kit, fully enclosed power pack fitted with isolator switch (12/ 24V) and oil tank, radio controlled cordless single speed remote.



# THE ULTIMATE UTILITY UPGRADE

## QL-080 COMPACT CRANES



### SPECIFICATIONS

Quicklift 080 Model Specifications	QL-080-1	QL-080-2
T/M	0.77	0.77
Distance at max. lift	1.1m	1.1m
Max lift	700kg	700kg
Max hyd. reach	2.1m	2.9m
Max hyd. lift	400kg	280kg
Max reach with manual ext.	2.9m	3.8m
Max lift with manual ext.	280kg	200kg
Standard crane weight	124kg	184kg
Base frame weight	35kg	35kg
Stowed crane height	1.346m	1.346m
Stowed crane length	0.547m	0.595m
Radio controlled	Inc	Inc
Mounting space	0.31m	0.31m

### Quicklift QL-080-1+1

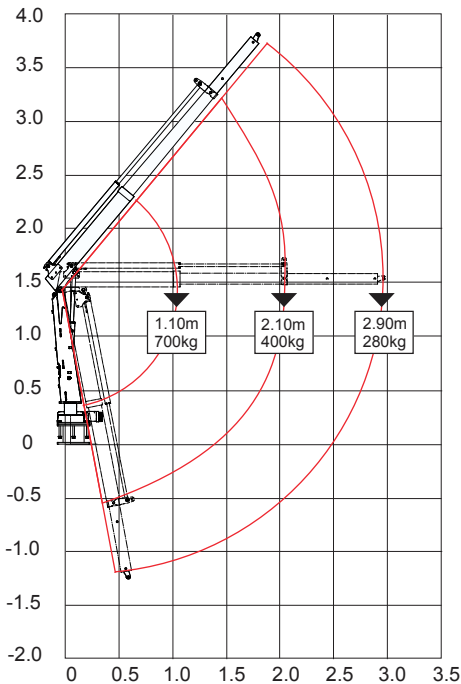

### Quicklift QL-080-2 with optional manual extension

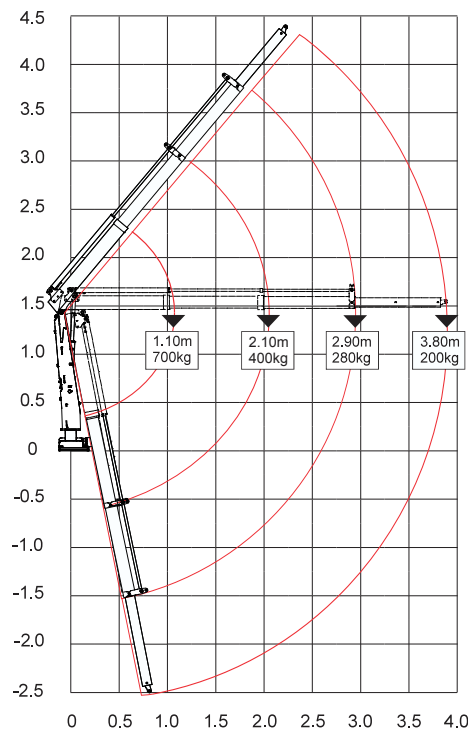

### Crane Dimensions

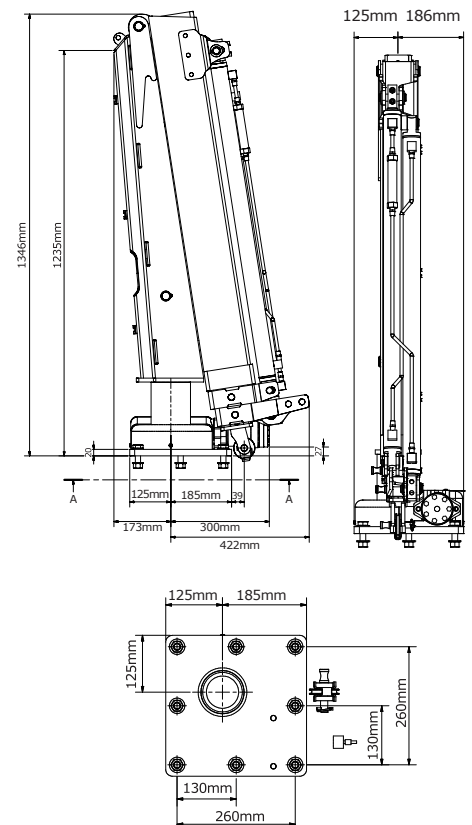

Quicklift Australia Distributor: Healy Group Pty Ltd

For sales, service and support, call Healy Group on 02 9525 5522 or visit our website at [healygroup.com.au](http://healygroup.com.au)